

# INOX | Saladette

SALADETTE ► GN1/1 ► STAINLESS STEEL TOP & DRAWERS

# CRD 92A



## DETAILS



## GENERAL FEATURES

- GN1/1 Refrigerated saladette (STAINLESS STEEL TOP & DRAWERS) •
- Stainless Steel exterior and interior •
- Static Cooling •
- Automatic compressor cycle defrost •
- Foaming Agent Cyclopentane (45mm per side) •
- Digital Thermostat •
- Sliding engine room for a manageable after sales servicing •
- Plastic thermal-braker as chamber body frame •
- Easy removable condenser filter •
- Separated plastic water tray •
- Front panel tilted holes for better air circulation •
- Adjustable shelves GN1/1: 1 Pcs + N.2 Drawers (GN1/1) •
- Self closing door (New inner embossed design for a better sealing) •
- Removable Gasket •
- Engine room lock fitted as standard •
- N.2 Adjustable feet in the front + N.4 fix rollers •
- Energy efficiency class: C •

## TECHNICAL SPECIFICATIONS

Capacity	<b>214L</b>
Temperature	<b>+0° - +8°C</b>
Consumption	<b>2.1 kWh/24h</b>
Rated Power	<b>142.4 W</b>
Noise level	<b>50 dB(A)</b>
Net Weight	<b>88 Kg</b>
Gross Weight	<b>109 Kg</b>
External Dimensions (WxDxH mm)	<b>900x700x880</b>
Internal Dimensions (WxDxH mm)	<b>810x586x492</b>
Packaging dimensions (WxDxH mm)	<b>960x775x1040</b>
Loading quantities 20'/40'/40"HQ	<b>36/72/72</b>

## PRODUCT DIMENSIONS

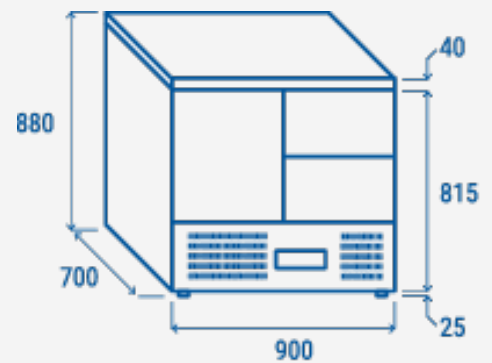

## CERTIFICATION

CE RoHS



**RIGHTWAY ASIA**  
We make the world a cooler place