

# INOX | Upright Cabinets

BAKERY REFRIGERATED CABINETS ▶ VENTILATED ▶ CHILLER

## PA 800TN



- Water droplets icon
- Fan icon
- GAS R290
- 60 mm
- 4 CLIMATIC CLASS
- 38°C
- Lightbulb icon
- LED
- Key icon
- Door icon

### DETAILS

- The items can be supplied either with adjustable feet or lockable castor
- Euronorm 600x400mm set of guides (10 Layer for each door)
- Main switch and digital thermostat fitted as standard
- Evaporator with anti-corrosion treatment



### GENERAL FEATURES

- EURONORM refrigerated upright cabinet
- Stainless Steel exterior and interior
- Ventilated Cooling
- Evaporator with anti-corrosion treatment
- Automatic compressor cycle defrost
- Foaming Agent Cyclopentane (60mm per side)
- Digital Thermostat
- Removable Gasket
- LED light and lock fitted as standard
- Door: Self closing and reversible door fitted as standard
- Set of 10 slides for bakery tray 600X800
- N.4 S/S Adjustable feet - (Lockable castor as Optional)
- Energy efficiency class: D

### TECHNICAL SPECIFICATIONS

Capacity	<b>800 L</b>
Temperature	<b>+2° - +8°C</b>
Consumption	<b>3.521 kWh/24h</b>
Rated Power	<b>230 W</b>
Noise level	<b>50 dB(A)</b>
Net Weight	<b>127 Kg</b>
Gross Weight	<b>139 Kg</b>
External Dimensions (WxDxH mm)	<b>740x990x2010</b>
Internal Dimensions (WxDxH mm)	<b>624x860x1396</b>
Packaging dimensions (WxDxH mm)	<b>765x1025x2070</b>
Loading quantities 20'/40'/40"HQ	<b>16/34/34</b>

### CERTIFICATION

CE RoHS

### PRODUCT DIMENSIONS

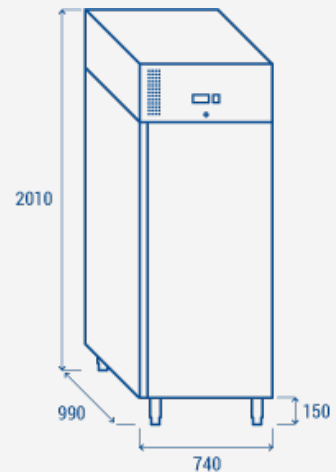

**RIGHTWAY ASIA**  
We make the world a cooler place