

DISPLAY | Countertop Displays

REFRIGERATED COUNTERTOP SHOWCASES



GENERAL FEATURES

- 120 Lt. Refrigerated countertop showcase
- Square glass with black frame and stainless steel basement
- Ventilated Cooling
- Automatic compressor cycle defrost
- Digital display control
- Interior LED light
- Anti-condensation double layer glass
- Rear sliding doors
- Adjustable chromed shelves (N.2 Pcs)
- N.4 fix support assembled under the basement
- Energy efficiency class: C

TECHNICAL SPECIFICATIONS

Capacity	120 L
Temperature	M2 (-1°C-+7°C)
Consumption	3.67 kWh/24h
Rated Power	160 W
Noise level	52 dB(A)
Net Weight	57 Kg
Gross Weight	60 Kg
External Dimensions (WxDxH mm)	700x570x685
Internal Dimensions (WxDxH mm)	665x485x410
Packaging dimensions (WxDxH mm)	773x627x855
Loading quantities 20'/40'/40"HQ	54/108/162

CERTIFICATION

CE RoHS



RC 120SQ

GAS R600a
M2 -1°C +7°C
ENERGY CLASS C
3 +25°C/60RH

LED
Water droplets icon
Fan icon

DETAILS

Stainless steel basement with digital controller

Cap in square tempered glass

Rear sliding doors

PRODUCT DIMENSIONS

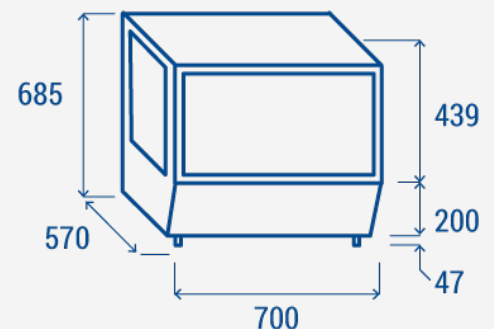

RIGHTWAY ASIA
We make the world a cooler place